

Continuous immobilized cell reactor for amide hydrolysis

N. Bernet^a, A. Thiéry^a, M. Maestracci^a, A. Arnaud^a, G.M. Rios^b and P. Galzy^a

^aChaire de Génétique et Microbiologie, Ecole Nationale Supérieure Agronomique and ^bCentre de Génie et de Technologie Alimentaire, Division Génie des Procédés, Université des Sciences et Techniques du Languedoc, Montpellier, France

Received 28 October 1986

Revised 3 April 1987

Accepted 8 April 1987

Key words: Fluidized bed reactor; Cell immobilization; Amide hydrolysis; *Brevibacterium*

SUMMARY

This article deals with continuous hydrolysis of acrylamide into acrylic acid using the wild-type *Brevibacterium* sp. R312 which can hydrolyze all water-soluble amides into their corresponding acids. Biotransformation has been carried out in a fluidized bed reactor specially designed to obtain good contact conditions between cells entrapped into small calcium alginate beads (2–3 mm) and low-concentration acrylamide solutions (10–40 g · l⁻¹). Different flow rates, biocatalyst loads and substrate concentrations have been investigated. Kinetic constants for the immobilized enzyme have been identified. It appears that the Michaelis constant does not change with operating conditions and remains roughly equal to the value obtained for free cells. In contrast, the maximum rate of hydrolysis is considerably decreased, as if only cells on the outskirts of beads were involved in the transformation. On the whole it is proved that corynebacteria cells could be usefully used for the bioconversion of amides in a continuous immobilized cell reactor; the higher the solid hold-up and/or the smaller the beads, the more efficient the biological transformation.

INTRODUCTION

Nowadays, nitriles are widely used in organic synthesis to produce chemical compounds such as amides and organic acids, that are of the greatest importance in industry in the manufacture of plastics, synthetic rubbers and fibers, insecticides, etc. However, conversion of nitriles in the traditional 'chemical' way presents several disadvantages:

– heating-energy consumption is high;

– reactions proceed in either strongly acid or basic media;

– by-product formation (with toxic substances such as H-C≡N) is important.

The newly investigated 'biological' procedure in which microorganisms are used as the catalyst is more attractive because pH and temperature conditions are less severe, and because very pure products are formed. However, the use of efficient microbes is necessary.

Just a few microbial strains are able to hydrolyze nitriles, such as *Arthrobacter* sp. J1 [5,6] and *Brevibacterium* sp. R312 [1–3]. The second one possesses two enzymes to perform conversion: a nitrile

Correspondence: A. Arnaud, Chaire de Génétique et Microbiologie, Ecole Nationale Supérieure Agronomique, Place Viala, 34060 Montpellier Cedex, France.

le-hydratase to transform nitriles into amides [4,10,12,40], and an amidase to transform amides into organic acids [24,28–30,37–39]. Other microbial amidases do exist, the activity and the biosynthesis of which have been investigated in several works, especially amidases from *Pseudomonas* sp. [8,13–16] and *Aspergillus nidulans* [19–23]. Amidase from *Brevibacterium* sp. R 312 has the advantage over the others of both being associated with a nitrile-hydratase and owning a wide substrate spectrum.

The present work more particularly examines the feasibility of biological amide hydrolysis in a continuous manner using amidase from *Brevibacterium* sp. R312. Acrylamide was tested as substrate. It is worth recalling that this compound may be obtained by either chemical [31] or biological [7,9,17,18,26,33,41–44] hydration of acrylonitrile. Reactions were carried out in a newly patented three-phase fluidized bed apparatus, the so-called 'High Compacting Multiphasic Reactor' (HCMR) [35].

CELL PRODUCTION

Bacterial strain

As already mentioned, the strain used was the wild-type *Brevibacterium* sp. R 312 [1–3].

Culture conditions

The basal minimum medium used for growing the *Brevibacterium* sp. R 312 strain had the following composition ($\text{g}\cdot\text{l}^{-1}$): KH_2PO_4 , 1.20; $\text{Na}_2\text{HPO}_4\cdot 12\text{H}_2\text{O}$, 1.95; K_2HPO_4 , 0.98; CaCl_2 , 0.012; ZnCl_2 , 0.0012; FeSO_4 , 0.0012; MnSO_4 , 0.0012. This medium was sterilized by autoclaving at 110°C for 35 min. A $\text{MgSO}_4\cdot 7\text{H}_2\text{O}$ solution and a thiamine hydrochloride solution were sterilized by membrane filtration (Millipore $0.45\ \mu\text{m}$) and added to the basal minimum medium at final concentrations of $0.5\ \text{g}\cdot\text{l}^{-1}$ and $0.002\ \text{g}\cdot\text{l}^{-1}$, respectively. Glucose was used as carbon source at a final concentration of $10\ \text{g}\cdot\text{l}^{-1}$. Nitrogen was provided by adding ammonium sulfate to $5\ \text{g}\cdot\text{l}^{-1}$ final concentration. Since the amidase from the *Brevibacterium* sp.

R 312 wild type is inducible [24,30,37], *N*-methylacetamide was added as inducer into the medium to $50\ \text{mM}$ final concentration.

Cultivation was performed using a Biolafite fermentor with a 15-l volume flask. Temperature was set to 28°C ; pH was regulated at 7.0; agitation was set at 500 rpm. The medium was inoculated with 1500 ml of a preculture grown in an Erlenmeyer flask containing the same medium. Aeration was performed by bubbling filtered air into the vessel. Cells were harvested during the log phase and frozen until used.

Counting of cells

Cells in suspension were counted using the nephelometry technique. Turbidity of solutions was measured with a Klett-Summerson colorimeter equipped with a blue filter (400–450 nm). A linear relationship was established between optical density and number of cells as follows: a suspension with $570\cdot 10^6\ \text{cells}\cdot\text{ml}^{-1}$ gives a 1.3 O.D. reading (or 650 Klett units).

APPARATUS AND METHODS

Cell immobilization

According to Miller and Knowles [32], diffusion of molecules (substrate or product) through the cellular membrane of *Brevibacterium* sp. is easy and does not constitute a limiting step for hydrolysis. For that reason, and in an attempt to simplify operating conditions, entire cells that may be viewed as 'bags of enzymes' were preferred to partially purified amidase.

To reduce catalyst losses by fluid transport, cells were immobilized following the method described by Svensson and Ottensen [36]. Microorganisms were first mixed with a solution of alginic acid (final concentration: $30\ \text{g}\cdot\text{l}^{-1}$) at pH 7.0. Then, this suspension was dripped from a capillary tube into an excess of 0.1 M calcium chloride. Small beads with a size mainly dependent on tube diameter were obtained, left to harden for at least 1 h, and finally, washed with saline (NaCl , $9\ \text{g}\cdot\text{l}^{-1}$).

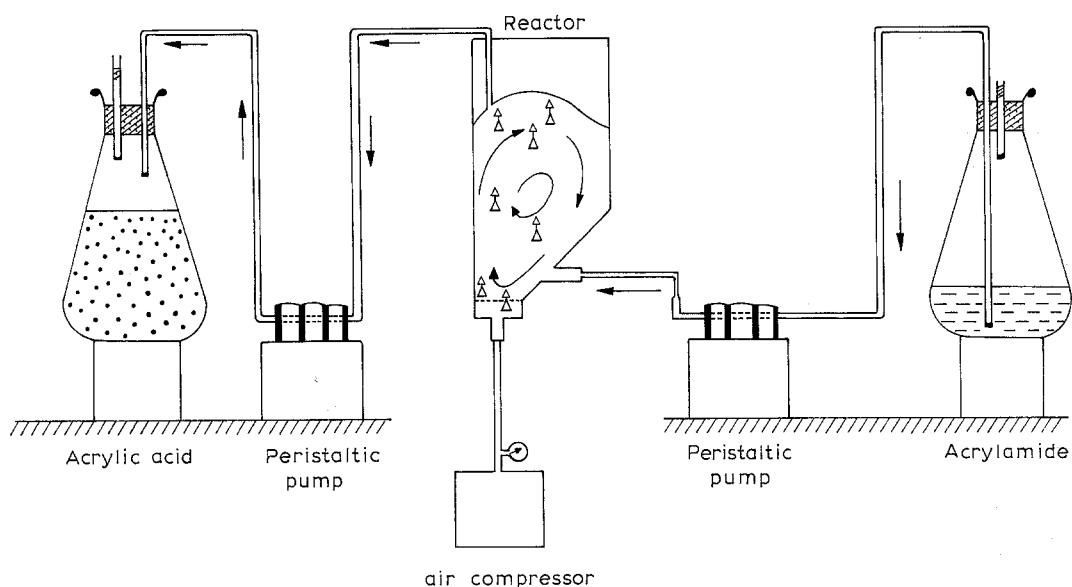

Fig. 1. Reactor set-up.

Pilot plant

To study immobilized amidase under continuous reactor operating conditions, a pilot plant was set up as shown in Fig. 1.

Basically, the HCMR [35] is a fluidized bed reactor which ensures a smooth and tight contact between liquid and solid phases, i.e., acrylamide solution and cell-supporting particles, thanks to a

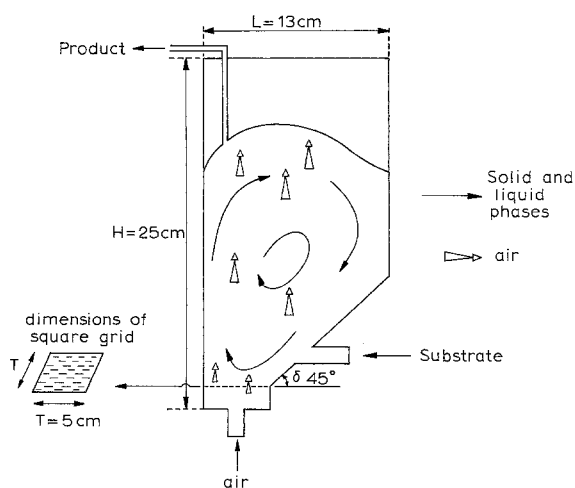

Fig. 2. Scheme of the fluidized bed reactor (HCMR).

specially designed gas distributor. The HCMR is characterized by the original configuration of its bottom plate built up from two components (Fig. 2):

- a horizontal grid uniformly distributing the gas so that a local upward particle transport is induced;
- an inclined deflector which brings back the solid phase towards the bubbling zone.

A whirling movement of the solid phase and of the dragged liquid is therefore promoted around a horizontal axis, setting up a real vortex. In addition, a low-amplitude and high-frequency movement of particles is superimposed on the overall motion. The HCMR is specially designed to operate in those cases where traditional fluidization appears to be inefficient: particles with sticky surfaces or flat-shaped particles, liquid and solid phases with nearly equal densities, etc.

A previous work [34] mainly concerned with the HCMR hydrodynamics has shown that:

- by analogy with traditional fluidization, a minimum gas velocity may be defined at which the whirling movement is set up, its value depending on particle shape and solid hold-up;
- gas hold-up is lower than in a traditional fluidized bed;

- liquid phase is perfectly mixed;
- solid hold-up may be as high as 50% (v/v);
- particles are not uniformly distributed through the reactor, but for aqueous solutions close to a 1 c.p. viscosity, segregation tendencies become significant if the density difference between liquid and solid increases beyond 10%;
- energy consumption for aeration is negligible.

In this work, acrylamide solutions, alginate beads and air were, respectively, the liquid, solid and gas phases.

Analytical methods

Enzyme activity as well as amide concentration were measured by the GLC technique previously presented by Jallageas et al. [25] and Bui et al. [11].

Working conditions

At the beginning of each run, the reactor was loaded with catalyst beads and then filled up with buffered acrylamide solution (0.02 M Tris-HCl, pH 7.0) in such a way that the total hold-up was equal to 0.9 l. Then, aeration was started, as well as liquid pumping. Gas velocity was chosen so that good whirling conditions prevailed. For various liquid flow rates, Q , conversion yield at steady-state, $(C_i - C_o)/C_i$, was evaluated by measuring outlet amide concentration, C_o .

From time to time, solid particles were replaced to prevent a decrease in whole enzyme activity due to swelling of beads and the resulting cell losses.

Several sets of experiments were performed at 20°C, changing inlet amide concentration, C_i , bead diameter, d , immobilized cell content, m (wet weight with nearly 15% dry matter), and solid hold-up, V_s .

Equations

On the assumption that perfect mixing conditions are obtained in the reactor and that diffusional effects are negligible, a simple mass balance leads to the following equation:

$$\tau = \frac{C_i - C_o}{r(C_o)} \quad (1)$$

with τ , the space-time, defined as the ratio of liquid

hold-up, V_L , to volumetric feed rate, Q , and $r(C_o)$ the rate of disappearance of acrylamide, which may be written:

$$r(C_o) = \frac{r_{\max} \cdot C_o}{K + C_o} \quad (2)$$

according to a Michaelis-Menten model. K is ordinarily referred to as the Michaelis constant, while r_{\max} is the maximum reaction rate that linearly varies as a function of 'useful' enzyme concentration.

Inserting the Michaelis-Menten equation into the mixed flow performance equation gives [27]:

$$\tau = \frac{(C_i - C_o)(K + C_o)}{r_{\max} \cdot C_o} \quad (3)$$

On rearrangement, we find an equation which allows a direct evaluation of r_{\max} and K (Fig. 3):

$$C_o = -K + r_{\max} \cdot \frac{C_o \tau}{C_i - C_o} \quad (4)$$

RESULTS AND DISCUSSION

Results are reported in Table 1 and in Figs. 4–9, with the kinetic constant values for immobilized cells, r_{\max} and K , determined by regression analysis in Fig. 5, 7 and 9. For comparison purposes, free cell characteristics under homogeneous conditions,

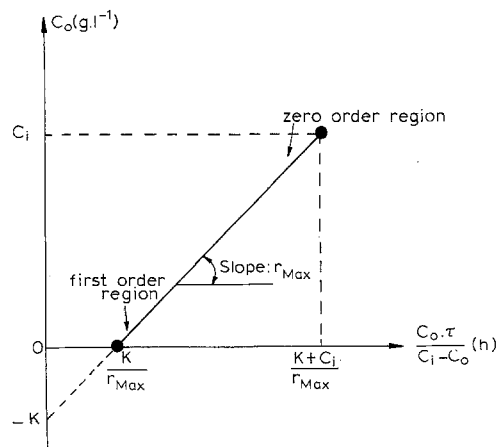

Fig. 3. Graphical determination of r_{\max} and K .

Table 1
Kinetic constant values

Results from Fig.	C_i (g.l ⁻¹)	d (mm)	V_S (l)	V_L (l)	m (g)	r_{max} (mol.h ⁻¹ .l ⁻¹)	r_{max}^o	$10^3 K$ (mol.l ⁻¹)	$10^3 K^o$	$\frac{r_{max}^o}{m} \cdot V_L$ (mol.h ⁻¹ .g ⁻¹)	$\frac{r_{max}^o}{r_{max}}$
4	10 20	3	0.28	0.62	15	0.18	3.25	14.2	10-16.0	0.13	18
6	10 20 30 40	2	0.34	0.56	25	0.34	4.30	14.2	10-16.0	0.10	13
8	10 10	2	0.34	0.56	32	0.44	5.50	14.2	10-16.0	0.10	13
		2	0.42	0.48	40	0.60	8.00	14.2	10-16.0	0.10	13

which are the same as those for partially purified amidase, have also been indicated (Table 1).

From Figs. 5 and 7, where $(C_o, \tau C_o / (C_i - C_o))$ coordinates have been adopted, it is clear that data points obtained with a given catalyst load at various liquid flow rates, and inlet substrate concentrations less than 30 g.l⁻¹, easily fit a straight line. This tends to indicate that estimated r_{max} and K values are intrinsic kinetic constants instead of apparent values, in agreement with the hypothesis on negligible diffusional effects. At low space times, τ , and

higher inlet concentrations, C_i , the observed deviation is certainly due to increased viscosity that results in worse mixing conditions and reduced reaction yields.

It is also worth noting from Table 1 that:
- amidasic activity of *Brevibacterium* is high (around 10⁻¹ mol.h⁻¹.g⁻¹ for free cells) and just slightly depends on harvest; obviously, cells prepared for the initial experiments (Fig. 4) had nearly the same enzyme content as the ones grown later (Figs. 6 and 8);

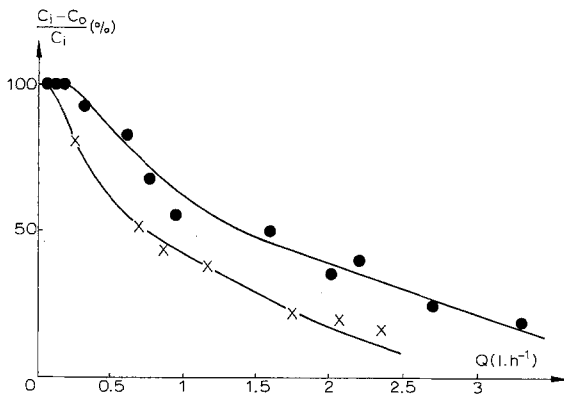

Fig. 4. Bioconversion yield as a function of volumetric feed rate. ●, $C_i = 10 \text{ g.l}^{-1}$; x, $C_i = 20 \text{ g.l}^{-1}$, $d = 3 \text{ mm}$, $m = 15 \text{ g}$, $V_S = 0.28 \text{ l}$, $V_L = 0.62 \text{ l}$.

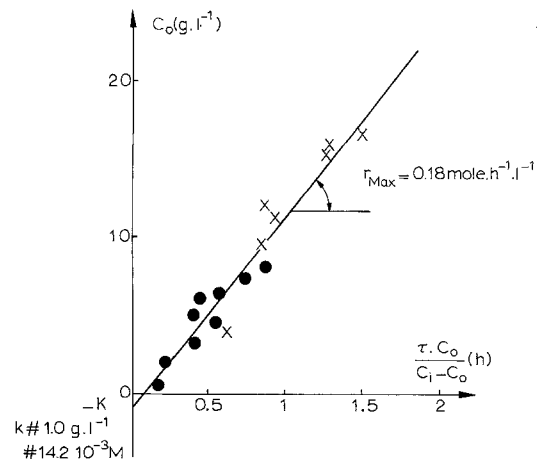

Fig. 5. Graphical determination of kinetic constants for the working conditions of Fig. 4.

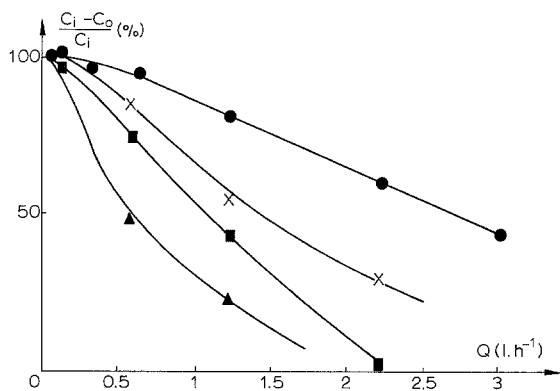

Fig. 6. Bioconversion yield as a function of volumetric feed rate. ●, $C_i = 10 \text{ g.l}^{-1}$; x, $C_i = 20 \text{ g.l}^{-1}$; ■, $C_i = 30 \text{ g.l}^{-1}$; ▲, $C_i = 40 \text{ g.l}^{-1}$. $d = 2 \text{ mm}$, $m = 25 \text{ g}$, $V_S = 0.34 \text{ l}$, $V_L = 0.56 \text{ l}$.

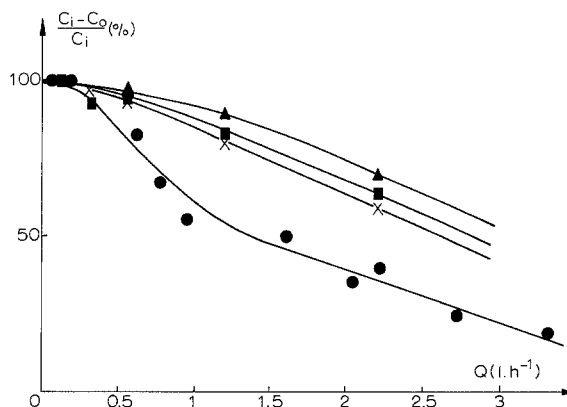

Fig. 8. Bioconversion yield as a function of volumetric feed rate ($C_i = 10 \text{ g.l}^{-1}$). ●, $d = 3 \text{ mm}$, $V_S = 0.28 \text{ l}$, $V_L = 0.62 \text{ l}$, $m = 15 \text{ g}$; x, $d = 2 \text{ mm}$, $V_S = 0.34 \text{ l}$, $V_L = 0.56 \text{ l}$, $m = 25 \text{ g}$; ■, $d = 2 \text{ mm}$, $V_S = 0.34 \text{ l}$, $V_L = 0.56 \text{ l}$, $m = 32 \text{ g}$; ▲, $d = 2 \text{ mm}$, $V_S = 0.42 \text{ l}$, $V_L = 0.48 \text{ l}$, $m = 40 \text{ g}$.

– the Michaelis constant for immobilized cells does not change with operating conditions; it is not significantly different from the one found for free cells: $K = 14 \cdot 10^{-3} \text{ mol.l}^{-1}$ against $K^\circ = 10 \cdot 10^{-3} - 16 \cdot 10^{-3} \text{ mol.l}^{-1}$ (Table 1). This result is logical, considering that diffusional effects are negligible;

– whatever the case, r_{max} is far less than r°_{max} ; more-

over, it appears that $r^\circ_{\text{max}}/r_{\text{max}}$ values decrease with d , suggesting that only cells on the outskirts of beads actually are active. Supposing that cells are homogeneously distributed within the gel, the active layer thickness has been estimated; for 2- and 3-mm beads, it has been found to be equal to $30 \mu\text{m}$: as a comparison, it may be kept in mind that *Brevibacterium* cells are rods between 4 and $9 \mu\text{m}$ in length and almost $1 \mu\text{m}$ in diameter.

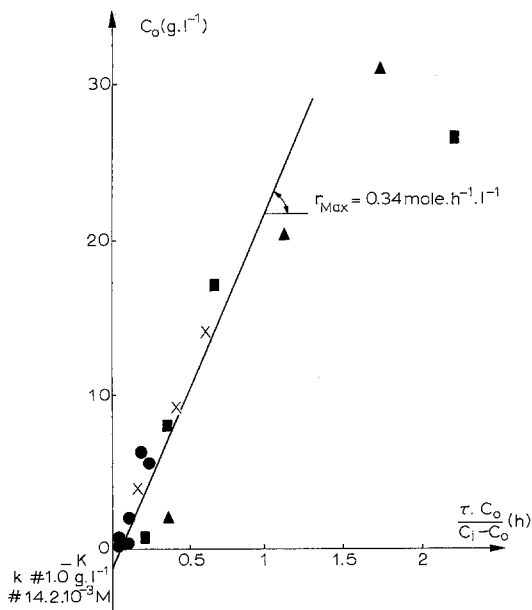

Fig. 7. Graphical determination of kinetic constants for the working conditions of Fig. 6.

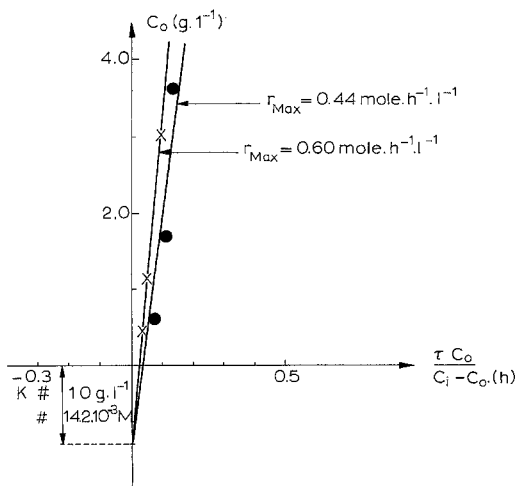

Fig. 9. Graphical determination of kinetic constants for the $m = 32 \text{ g}$ and $m = 40 \text{ g}$ working conditions of Fig. 8.

Finally, with regard to industrial applications, several salient features are also to be underlined and commented upon:

- the HCMR is very efficient for treating solutions of low concentration; it allows a quick and complete conversion of large volumes in small-size apparatuses and at low expense; problems ordinarily encountered in fixed bed units disappear: poor contact of phases due to bad percolation of liquid through solids, clogging which appears in the long run as a consequence of swelling of grains, high energy demands for pumping solutions, etc;
- the reactor performance is improved by increasing solid hold-up and/or decreasing particle size (Fig. 8), but it becomes worse when concentration is increased (Figs. 4 and 6) because of a deterioration in mixing conditions due to higher viscosity; in the latter case, it is reasonable to think that results could be improved by increasing particle density;
- in the long run, cell losses take place as a consequence of swelling of alginate beads; this phenomenon becomes more critical as acrylamide solutions are more concentrated.

CONCLUSIONS

This work clearly shows that the use of immobilized cells of *Brevibacterium* sp. R312 in a fluidized bed reactor (HCMR) continuously fed with low-concentration solutions is a very promising way of performing biological hydrolysis of amides into organic acids.

With the help of a simple graphical method, kinetic constant values for catalysts may be reached. From the ones here obtained, it can be concluded that inclusion does not modify basic enzyme attack mechanisms. From a fundamental viewpoint, this result constitutes a new argument in support of the idea that using corynebacteria for metabolite production in modern fermentation processes is particularly interesting. Indeed, corynebacteria cells may be viewed as 'bags' that prevent enzyme loss without introducing diffusional product limitations. In this case, with regard to practical developments, purification of enzymes appears to be use-

less, which induces reduced cost and simplified operation.

REFERENCES

- 1 Arnaud, A., P. Galzy and J.C. Jallageas. 1976. Remarques sur l'activité nitrilasique de quelques bactéries. C.R. Acad. Sci. Paris 283: 571–573.
- 2 Arnaud, A., P. Galzy and J.C. Jallageas. 1976. Etude de l'activité nitrilasique de quelques bactéries. Rev. Ferment. Ind. Aliment. 31: 39–44.
- 3 Arnaud, A., P. Galzy and J.C. Jallageas. 1976. Amidase activity of some bacteria. Folia Microbiol. 21: 178–184.
- 4 Arnaud, A., J.C. Jallageas and P. Galzy. 1977. Etude de l'acétonitrilase d'une souche de *Brevibacterium*. Agric. Biol. Chem. 41: 2183–2191.
- 5 Asano, Y., K. Fujishiro, Y. Tani and H. Yamada. 1982. Aliphatic nitrile hydratase from *Arthrobacter* sp. J-1. Purification and characterization. Agric. Biol. Chem. 46: 1165–1174.
- 6 Asano, Y., M. Tachibana, Y. Tani and H. Yamada. 1982. Purification and characterization of an amidase which participates in nitrile degradation. Agric. Biol. Chem. 46: 1175–1181.
- 7 Asano, Y., T. Yasuda, Y. Tani and H. Yamada. 1982. A new enzymatic method of acrylamide production. Agric. Biol. Chem. 46: 1183–1189.
- 8 Brown, P.R., M.J. Smyth, P.H. Clarke and M.A. Rosemeyer. 1973. The sub-unit structure of the aliphatic amidase from *Pseudomonas aeruginosa*. Eur. J. Biochem. 34: 177–187.
- 9 Bui, K., A. Arnaud and P. Galzy. 1982. A new method to prepare amides by bioconversion of corresponding nitriles. Enzyme Microb. Technol. 4: 195–197.
- 10 Bui, K., H. Fradet, A. Arnaud and P. Galzy. 1984. A nitrile hydratase with a wide substrate spectrum produced by a *Brevibacterium* sp. J. Gen. Microbiol. 130: 89–93.
- 11 Bui, K., H. Fradet, A. Thiéry, M. Maestracci, A. Arnaud and P. Galzy. 1984. Use of nuclear magnetic resonance and gas-liquid chromatography for the study of microbial nitrile-hydratases and amidases. Anal. Chim. Acta 163: 315–322.
- 12 Bui, K., M. Maestracci, A. Thiéry, A. Arnaud and P. Galzy. 1984. A note on the enzymic action and biosynthesis of a nitrile hydratase from a *Brevibacterium* sp. J. Appl. Bacteriol. 57: 183–190.
- 13 Clarke, P.H. 1970. The aliphatic amidases of *Pseudomonas aeruginosa*. Adv. Microbiol. Physiol. 4: 179–222.
- 14 Clarke, P.H. 1972. Biochemical and immunological comparison of aliphatic amidases produced by *Pseudomonas* sp. J. Gen. Microbiol. 71: 241–257.
- 15 Clarke, P.H. 1974. Amidases of *Pseudomonas* species. Biochem. Soc. Trans. 2: 831–834.
- 16 Clarke, P.H., M.A. Houldsworth and M.D. Lilly. 1968. Catabolism repression and the induction of amidase synthesis

- by *Pseudomonas aeruginosa* 8602 in continuous culture. *J. Gen. Microbiol.* 51: 225-234.
- 17 Fradet, H., A. Arnaud, G. Rios and P. Galzy. 1985. Hydration of nitriles using a bacterial nitrile hydratase immobilized on DEAE-cellulose. *Biotechnol. Bioeng.* 27: 1581-1585.
 - 18 Galzy, P., A. Arnaud, A. Commeyras and J.C. Jallageas. 1974. Procédé de préparation d'amides par hydrolyse biologique. French Patent No. 74,41828.
 - 19 Hynes, M.J. 1970. Induction and repression of amidase enzyme in *Aspergillus nidulans*. *J. Bacteriol.* 103: 482-487.
 - 20 Hynes, M.J. 1975. Amide utilization in *Aspergillus nidulans*. Evidence for a third amidase enzyme. *J. Gen. Microbiol.* 91: 99-109.
 - 21 Hynes, M.J. and J.A. Pateman. 1970. The use of amides as nitrogen sources by *Aspergillus nidulans*. *J. Gen. Microbiol.* 63: 317-324.
 - 22 Hynes, M.J. and J.A. Pateman. 1970. The genetic analysis of regulation of amidase synthesis in *Aspergillus nidulans*. I. Mutants able to utilize acrylamide. *Mol. Gen. Genet.* 108: 79-106.
 - 23 Hynes, M.J. and J.A. Pateman. 1970. The genetic analysis of regulation of amidase synthesis in *Aspergillus nidulans*. II. Mutants resistant to fluoroacetamide. *Mol. Gen. Genet.* 108: 107-116.
 - 24 Jallageas, J.C., A. Arnaud and P. Galzy. 1978. Etude de l'acétamidase d'une souche de *Brevibacterium*. *J. Gen. Appl. Microbiol.* 24: 103-114.
 - 25 Jallageas, J.C., A. Arnaud and P. Galzy. 1978. Application de la chromatographie en phase gazeuse à l'étude des nitrilases et amidases. *J. Chromatogr.* 166: 181-187.
 - 26 Jallageas, J.C., A. Arnaud and P. Galzy. 1980. Bioconversion of nitriles and their applications. *Adv. Biochem. Eng.* 14: 1-32.
 - 27 Levenspiel, O. 1979. Enzyme fermentation. In: *The Chemical Reactor Omnibook*. Ch. 81 OSU Book Stores, Corvallis, OR, U.S.A.
 - 28 Maestracci, M., K. Bui, A. Thiéry, A. Arnaud and P. Galzy. 1984. A study of the inhibition of an amidase with a wide substrate spectrum and its consequences for the bioconversion of nitriles. *Biotechnol. Lett.* 6: 149-154.
 - 29 Maestracci, M., A. Thiéry, A. Arnaud and P. Galzy. 1986. A study of the mechanism of the reaction catabolized by the amidase of *Brevibacterium* sp. R 312. *Agric. Biol. Chem.* 50: 2237-2241.
 - 30 Maestracci, M., A. Thiéry, K. Bui, A. Arnaud and P. Galzy. 1984. Activity and regulation of an amidase (acylamide amidohydrolase E.C.3.5.1.4.) with a wide substrate spectrum from a *Brevibacterium* sp. *Arch. Microbiol.* 138: 315-320.
 - 31 Matsuda, F. and N. Hashimoto. 1976. Acrylamide par hydratation catalytique directe. *Inf. Chim.* 160: 223-227.
 - 32 Miller, J.M. and C.J. Knowles. 1984. The cellular location of nitrilase and amidase enzymes of *Brevibacterium* sp. R 312. *FEMS Microbiol. Lett.* 21: 147-151.
 - 33 Nitto Chemical Industry Co, Ltd. 1979. Procédé de préparation de l'acrylamide et du méthacrylamide à l'aide de microorganismes. French Patent No. 79, 07935.
 - 34 Papaconstantinou, S., S. Elmaleh and G.M. Rios. 1986. Hydrodynamics and mass transfer in a high compacting multiphasic reactor. In: *Heat and Mass Transfer in Fixed and Fluidized Beds*. (Van Swaaij, W.P.M. and N.H. Afgan, eds.), pp. 711-718, Hemisphere Publication Corp., Washington, New York and London.
 - 35 Rios, G.N., J.L. Baxerres and H. Gibert. 1979. Procédé de mise en contact d'une phase gazeuse, d'au moins une phase liquide et d'au moins une phase solide à l'état divisé. French Patent No. 79, 17430.
 - 36 Svensson, B. and M. Ottensen. 1981. Entrapment of chemical derivatives of glyco-amylase in calcium alginate gels. *Carlsberg Res. Commun.* 46: 13-24.
 - 37 Thiéry, A., M. Maestracci, A. Arnaud and P. Galzy. 1985. Induction de l'amidase d'une souche de *Brevibacterium* sp. Structure chimique de l'inducteur. *Belgian J. Food Chem. Biotechnol.* 40: 115-117.
 - 38 Thiéry, A., M. Maestracci, A. Arnaud and P. Galzy. 1986. Acyltransferase activity of the wide spectrum amidase of *Brevibacterium* sp. *J. Gen. Microbiol.* 132: 2205-2208.
 - 39 Thiéry, A., M. Maestracci, A. Arnaud, P. Galzy and M. Nicolas. 1986. Purification and properties of an acylamide amidohydrolase (E.C.3.5.1.4.) with a wide activity spectrum from *Brevibacterium* sp. R 312. *J. Basic Microbiol.* 26: 299-311.
 - 40 Tourneix, D., A. Thiéry, M. Maestracci, A. Arnoud and P. Galzy. 1986. Regulation of nitrile hydratase synthesis in a *Brevibacterium* species. *Antonie Van Leeuwenhoek* 52: 173-182.
 - 41 Watanabe, I., K. Sakashita and Y. Ogawa. 1981. Procédé de préparation de l'acrylamide à l'aide de cellules immobilisées d'un type nouveau. French Patent No. 81, 15932.
 - 42 Watanabe, I. and Y. Satoh. 1980. Procédé pour préparer une solution aqueuse stable d'acrylamide ou de méthacrylamide à l'aide de microorganismes. French Patent No. 80, 03188.
 - 43 Watanabe, I., Y. Satoh and T. Takano. 1979. Acrylamide and methacrylamide produced using microorganisms. *Ger. Offen.* 2,912,292.
 - 44 Yamaguchi, Y., I. Watanabe and Y. Satoh. 1980. Procédé microbiologique pour la production d'une solution aqueuse d'acrylamide fortement concentrée. French Patent No. 80, 13635.